



X3-ATX-500

16-28v Input 500w Output DC-DC ATX Power Supply

SPECIAL FEATURES

- ✧ Small, Silent and Smart PSU [S³PSU]
- ✧ Operates at Wide Range Input Voltage [16V-28V]
- ✧ High Efficiency [>90%]
- ✧ Microcontroller Inside with Intelligent ATX Timing Control
- ✧ Highly Reliable Electrolytic Capacitors
- ✧ OCP, OVP, and OTP
- ✧ Heatsink on Top and Backplate at Bottom Included
- ✧ Board size: 150mm (L) x 85mm (W) x 25mm (H)

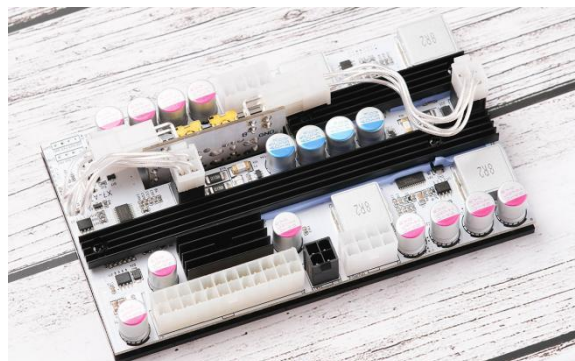

DC INPUT

NO.	DC Input Voltage	DC Jack	DC Input Cable Length
1	16V-28V (OVP at 28.2~28.5V)	7.4mm x 5.0mm	25mm
2	16V-28V (OVP at 28.2~28.5V)	7.4mm x 5.0mm	25mm

Note 1: The maximum output power falls off linearly as input voltage increases.





Note 2: The two DC input connectors are not connected. Users can either connect them together and use one single power source, or use two separate power adapters with different output voltages (such as one 19V, and the other 24V).

POWER RATINGS

Voltage Rail	Max Load (A)	Peak Load (A)	Regulation
+5V	8	10	±1.5%
+5VSB	2.5	3	±1.5%
+3.3V	8	10	±1.5%
-12V	0.05	0.1	±5.0%
+12V (channel 1)	18	22	±1.5%
+12V (channel 2)	18	22	±1.5%

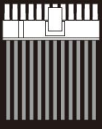
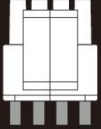
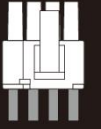
Note: Forced air ventilation is required for operating at max load. For fanless or improper ventilation operation derate the output of the 3.3 and 5V rails until PSU temperature falls below 65°C. Peak load should not exceed 60 seconds. Combined max power output should not exceed more than 500 Watts.

WIRE & CONNECTOR CONFIGURATION

Connector						
Model	Main Power (20P+4P) 350mm	EPS 12V (4P+4P) 420mm	PCI-E (6P+2P) 420mm	SATA 300mm	Peripheral (4P)	FDD (4P)
X7-ATX-500	1	1	2	3	1	0

PROTECTION

Overload Protection

The power supply will be shutdown and latch off when load power over 110% ~ 160% of the rated DC output.

Over Current Protection

The power supply shall have current limit to prevent the +12V, +5V and +3.3V outputs from exceeding the values shown in the following table. If the current limits are exceeded the power supply shall shutdown and latch off.

Rail	Over Current Limit
+12V	22A min, 25A max
+5V	10A min, 12A max
+3.3V	10A min, 12A max

Over Voltage Protection

The microcontroller in the PSU monitors all output rails and provides over voltage protection as defined in the following table.

Rail	Min (V)	Norm (V)	Max (V)
+12V	13.4	15	15.6
+5V	5.74	6.3	7
+3.3V	3.76	4.2	4.3

Short Circuit Protection

An output short circuit is defined as any output impedance of less than 0.1 ohms. The power supply shall shut down and latch off for shorting the +3.3V, +5V, or +12V rails to return or any other rail.

No Load Operation

No damage or hazardous condition should occur with all the DC output connectors disconnected from the load. The PSU may latch into shutdown state.

ENVIRONMENT

Operation

Operating temperature from -10°C to 70°C . Maximum output power falls off linearly as operating temperature increases from 40°C .

Shipping and Storage

Shipping and storage temperature from -40°C to 80°C . Relative humidity to 95% non-condensing.

Altitude

Operating 10,000FT max. Storage 50,000FT max.

SAFETY & EMC

Safety Standards

Currently no. Can apply for safety certificate according to customer's requirement.

EMC Emission

Currently no test results.

OTHERS

MTBF

The demonstrated MTBF (mean time between failures) shall be 100,000 hours of continuous operation at 25°C of full load at normal DC input. The MTBF of the power supply shall be calculated in accordance with MIL-HDBK-217F.

Dimension

150mm (L) x 85mm (W) x 25mm (H).

Weight

340 grams excluding cables. 490 grams including cables.

Package Content

One PSU, one ATX cable kit, and two DC input cables.

I/O PIN DIAGRAM

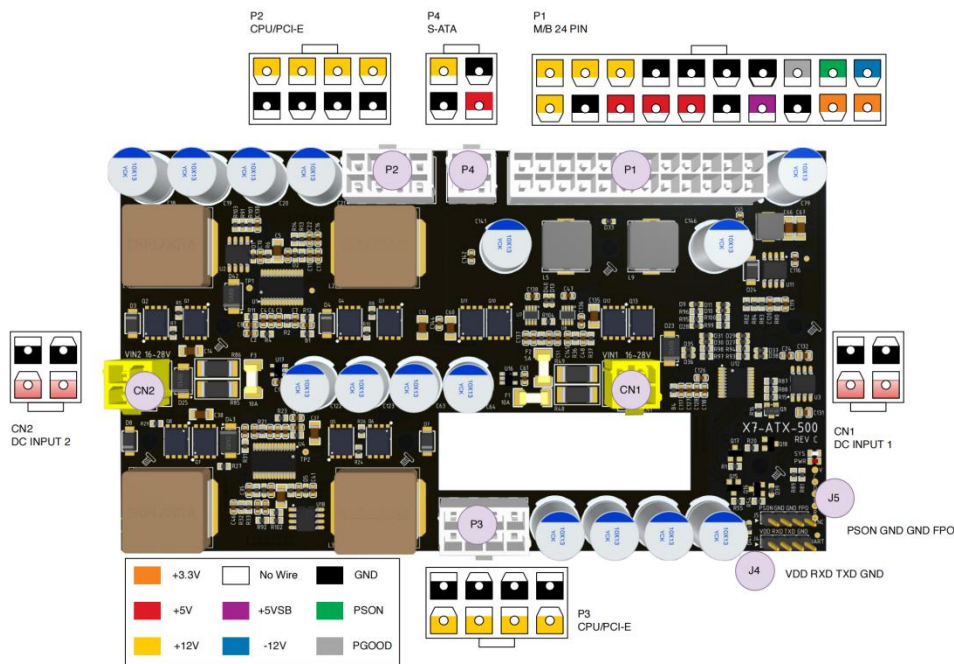

Note: J4 4-pin connector is for UART communication for power supply status monitoring. J5 4-pin connector is for synchronization between power supplies.

SERIAL COMMUNICATION

Communication mode: baud rate 115200, no parity check, 8 bits data, 1 stop bit

Data protocol is defined in the following table. Please contact technique expert of Pico-Box if you want to use serial communication.

NO.	0-1	2	3	4-5	6-7	8-9	10-11	12-13	14-15	16-17
Octets	2	1	1	2	2	2	2	2	2	2
Name	Head	Seq	State	IN_A	PGL	VS12_1	VS12_2	VS5	VS3	Check
Description	0xAA 0x55	Sequence no.	00: IDLE 02: RUN 03: OVP	Input current in mA	Scaled input voltage, mV	12V output rail, mV	The second 12V output rail, mV	5V output rail, mV	3.3V output rail, mV	Check sum

TIMING

Compliance with Intel ATX specification version 2.01. Remote ON/OFF control: 1) When the logic level "PS-ON" is low, the DC outputs are to be enabled. 2) When the logic level is high or open collector, the DC outputs are to be disabled.

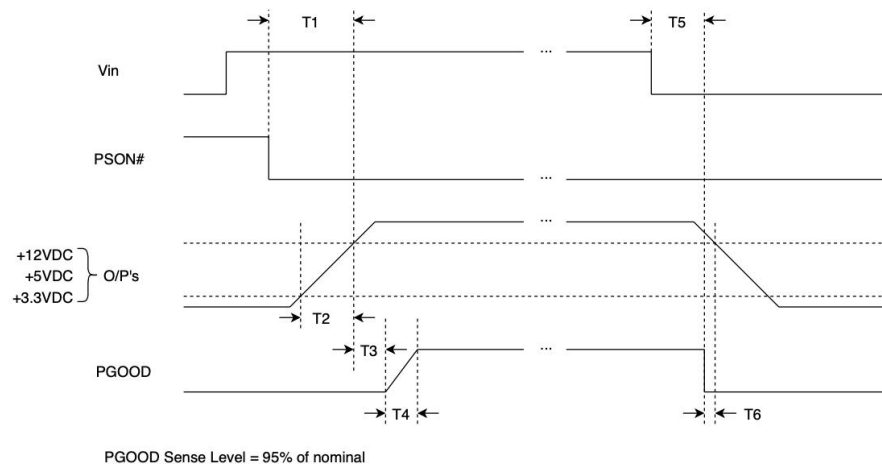

- T1: Power-on time. The time from when PSON# is pulled low to when the +12V, +5V and +3.3V outputs are within the regulation ranges. The power-on time shall be less than 500ms ($T1 < 500ms$)
- T2: Rise time. The output voltages shall rise from $\leq 10\%$ of nominal to within the regulation ranges within 0.1 ms to 20 ms ($0.1 \leq T2 \leq 20ms$)
- T3: Power good signal turn on delay time ($100 < T3 < 500ms$)
- T4: Power good signal rise time ($T4 \leq 10ms$)
- T5: Voltage input loss to PGOOD hold-up time ($T5 \geq 16ms$)
- T6: Power down warning ($T6 \geq 1ms$)

CABLE DIAGRAM

ATX Output Cable

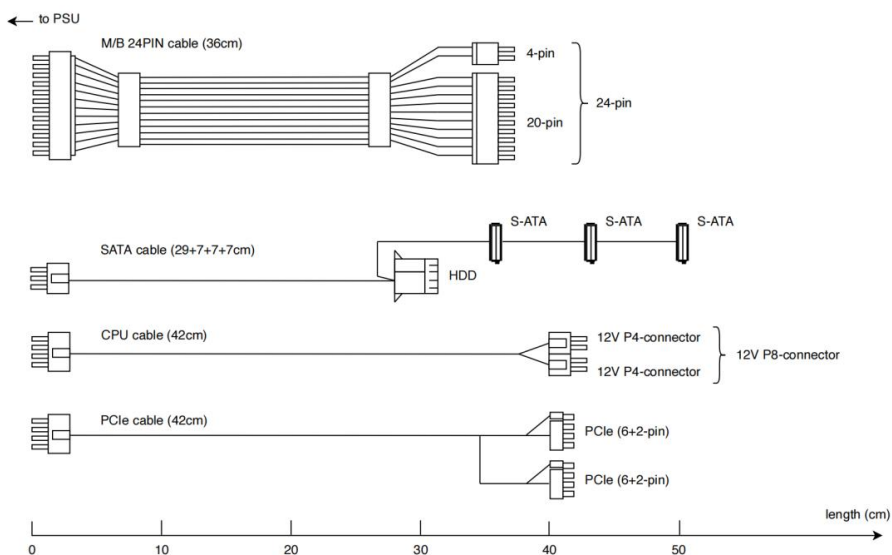

BACKPLANE

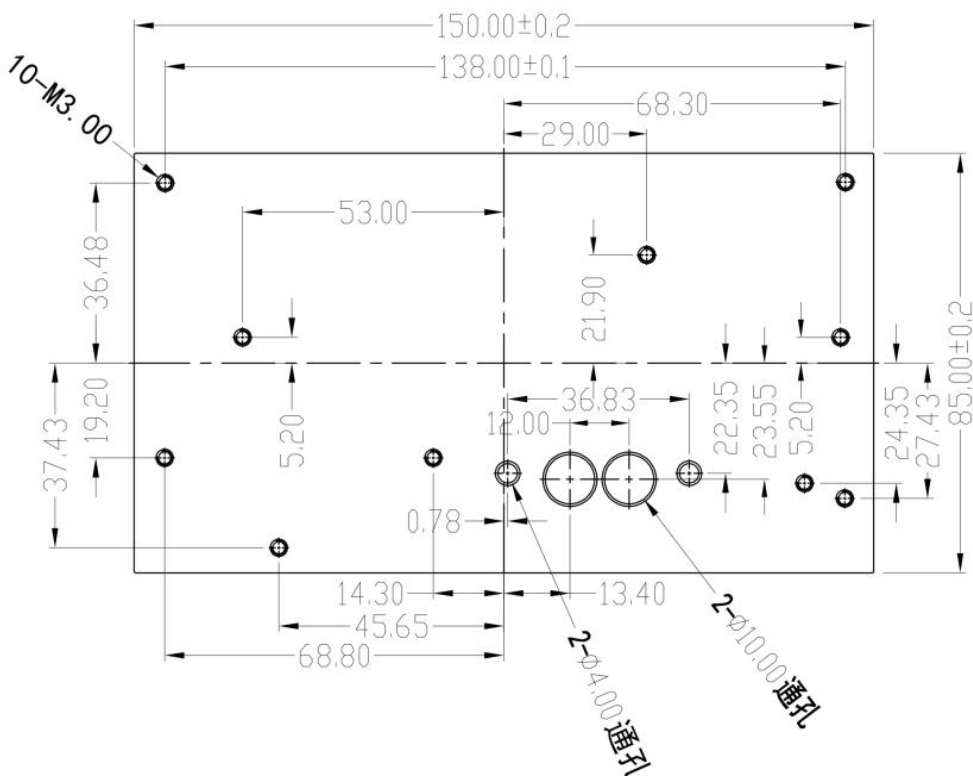

Note: Unit is mm. The mounting holes are compatible with that of the standard ATX power supply.

CONTACT

Pico-Box Technology Limited

Address: 901 Bldg 3, Silver Star Intelligent Community II, Guanlan, Longhua, Shenzhen 518110, P. R. China

Website: www.pico-box.com

Email: oversea@pico-box.com

